

8Mbyte Size 2 TRAM

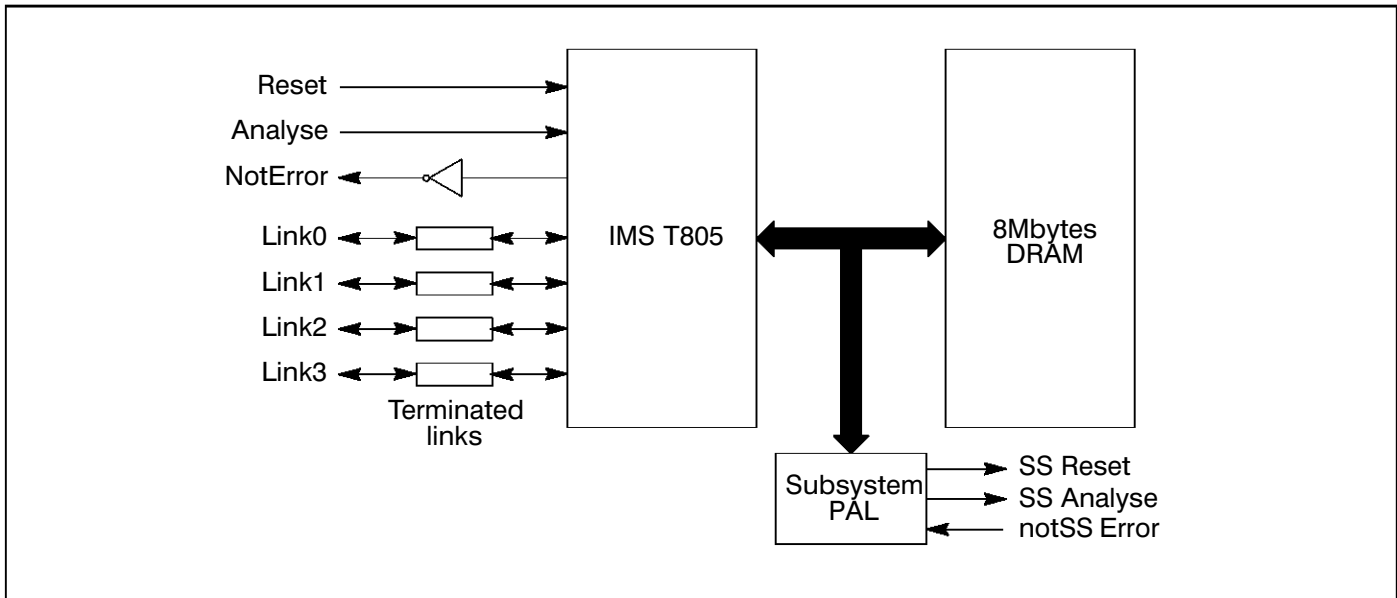

**FEATURES**

- 25MHz IMS T805 Transputer
- 8 Mbyte of zero wait-state DRAM (120ns memory cycle time)
- Size 2 TRAM
- Communicates via 4 INMOS serial links
- Package has only 16 active pins
- Subsystem control circuitry
- Designed to a published specification (*INMOS Technical Note 29*).

**DESCRIPTION**

The IMS B427 is a compact size 2 TRAM offering 8Mbytes of 4-cycle DRAM and subsystem controller circuitry.

With a large amount of external memory, the B427 is able to run all of the INMOS development tools. It is ideally suited for applications using large amounts of memory, allowing programs such as simulation and AI evaluation to run quickly and efficiently.

## 1.7 Specification

| TRAM feature                 | IMS B427-16 | Unit  | Notes |
|------------------------------|-------------|-------|-------|
| Transputer type              | T805-25     |       |       |
| Number of transputers        | 1           |       |       |
| Number of INMOS serial links | 4           |       |       |
| Amount of SRAM               | None        |       |       |
| SRAM 'wait -states'          | N/A         |       |       |
| Amount of DRAM               | 8           | Mbyte |       |
| DRAM 'wait -states'          | 0           |       |       |
| Memory cycle time            | 120         | ns    |       |
| Subsystem controller         | Yes         |       |       |
| Peripheral circuitry         | None        |       |       |
| Parity                       | No          |       |       |
| Size (TRAM size)             | 2           |       |       |
| Length                       | 3.66        | inch  |       |
| Pitch between pins           | 3.30        | inch  |       |
| Width                        | 2.15        | inch  |       |
| Component height above PCB   | 9.2         | mm    |       |
| Component height below PCB   | 3.1         | mm    | 1     |
| Weight                       | 63          | g     |       |
| Storage temperature          | 0–70        | °C    |       |
| Operating temperature        | 0–50        | °C    | 2     |
| Power supply voltage (VCC)   | 4.75–5.25   | Volt  |       |
| Power consumption            | 4.6         | W     | 3     |

Table 1.4 IMS B427 specification

### Notes

- 1 This dimension includes the thickness of the PCB.
- 2 The figure quoted refers to the ambient air temperature.
- 3 The power consumption is the worst case value obtained when a sample of IMS B427 TRAMs were tested (running a program that utilised all four links and accessed memory simultaneously) at a supply voltage (VCC) of 5.25 V.

## 1.8 Ordering Information

| Description                    | Order Number |
|--------------------------------|--------------|
| IMS B427 TRAM with IMS T805-25 | IMS B427-16  |

Table 1.5 Ordering information

---

Information furnished is believed to be accurate and reliable. However, SGS-THOMSON Microelectronics assumes no responsibility for the consequences of use of such information nor for any infringement of patents or other rights of third parties which may result from its use. No license is granted by implication or otherwise under any patent or patent rights of SGS-THOMSON Microelectronics. Specifications mentioned in this publication are subject to change without notice. This publication supersedes and replaces all information previously supplied. SGS-THOMSON Microelectronics products are not authorized for use as critical components in life support devices or systems without express written approval of SGS-THOMSON Microelectronics.

© 1995 SGS-THOMSON Microelectronics - All Rights Reserved

 , **inmos** , IMS, occam and DS-Link are trademarks of SGS-THOMSON Microelectronics Limited.

 is a registered trademark of the SGS-THOMSON Microelectronics Group.

SGS-THOMSON Microelectronics GROUP OF COMPANIES

Australia - Brazil - France - Germany - Hong Kong - Italy - Japan - Korea - Malaysia - Malta - Morocco -  
The Netherlands - Singapore - Spain - Sweden - Switzerland - Taiwan - Thailand - United Kingdom - U.S.A.